

SCHEMATICS

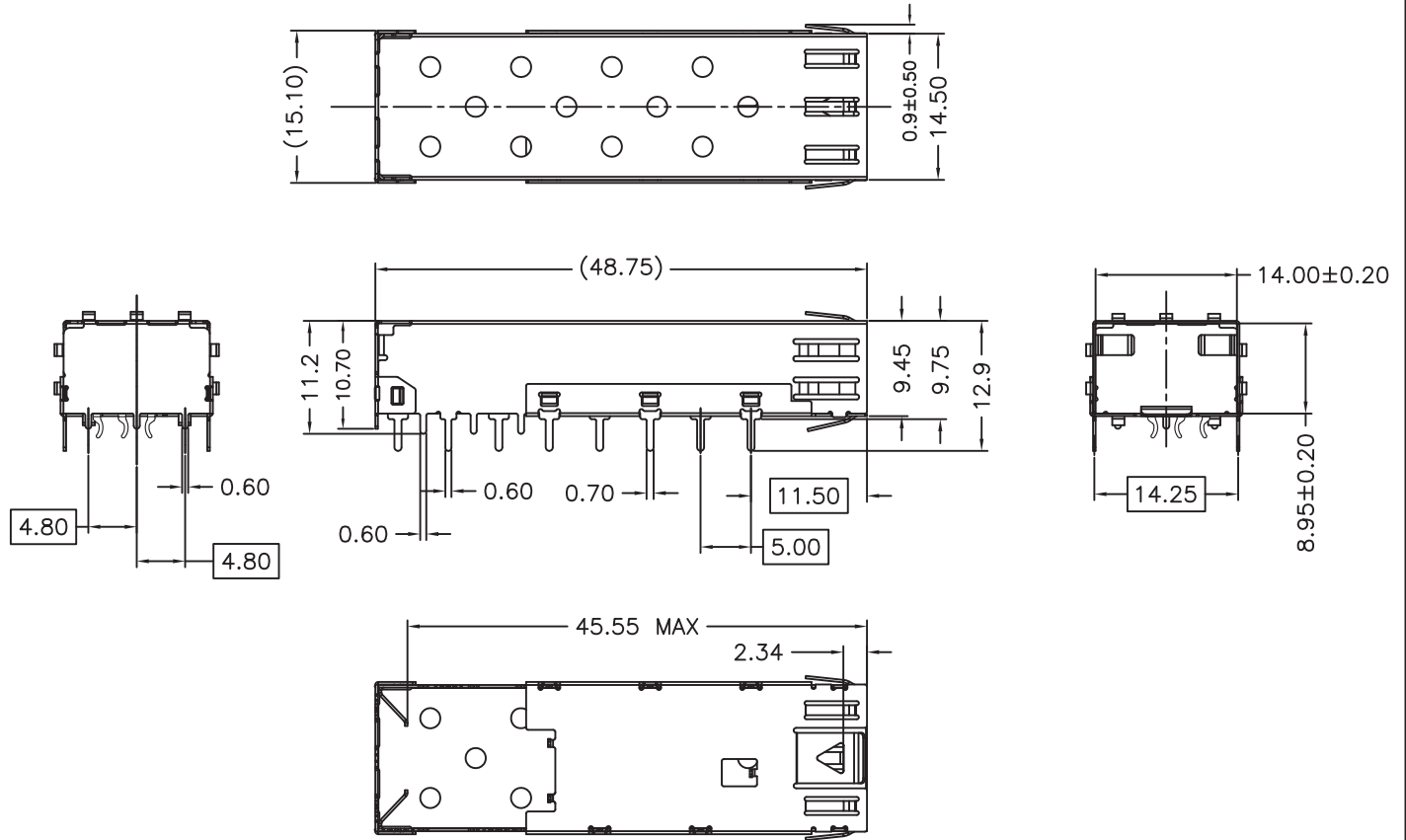

NOTES:

- 1.MATERIAL: NICKEL SILVER, THICKNESS 0.25mm
- 2.PACKAGING: TRAY PACKAGING
- 3.TEMPERATURE RANGE: -55°C TO +85°C



Drafted by:ZhangXuan

Dimensions:mm
Unless otherwise specified, all tolerances are ± 0,25

SFP1x1 cage

Approved By: TSLEE

Part No:SFP011PB

REV.
A

SHEET 1 OF 3

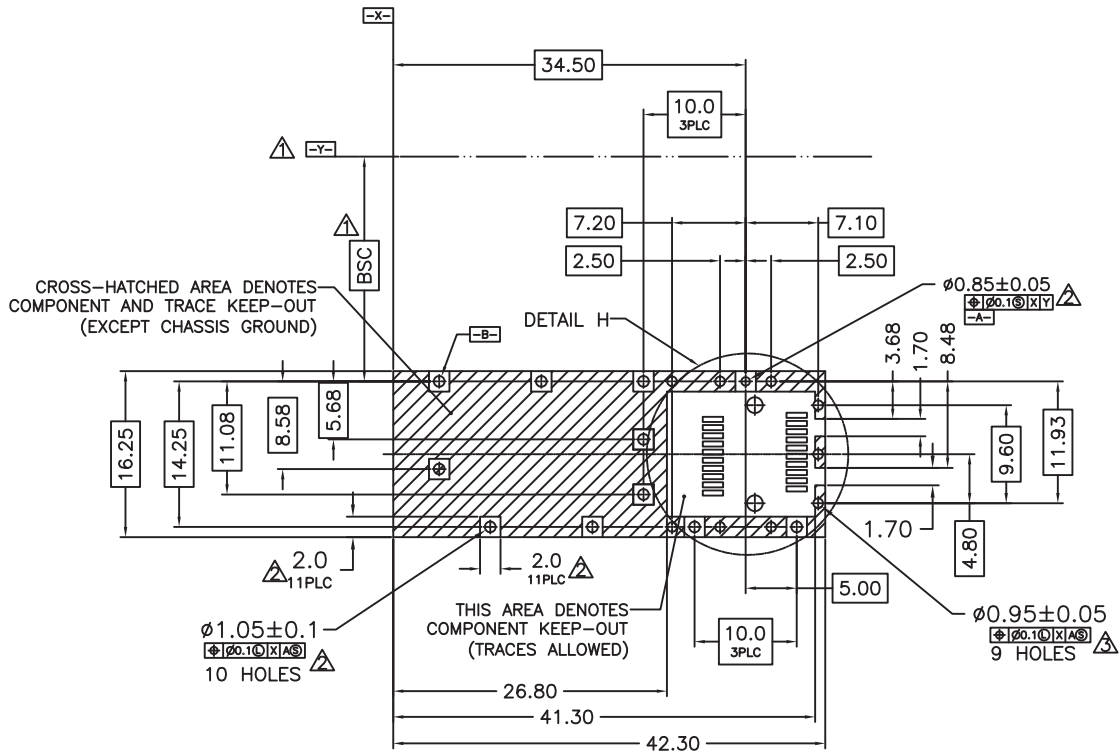

ECOMMENDED PCB CONFIGURATION

NOTES:

- 1. DATUM AND BASIC DIMENSIONS ESTABLISHED BY CUSTOMER
- 2. PADS AND VIAS ARE CHASSIS GROUND, 11 PLACES
- 3. THRU HOLES, PLATING OPTIONAL

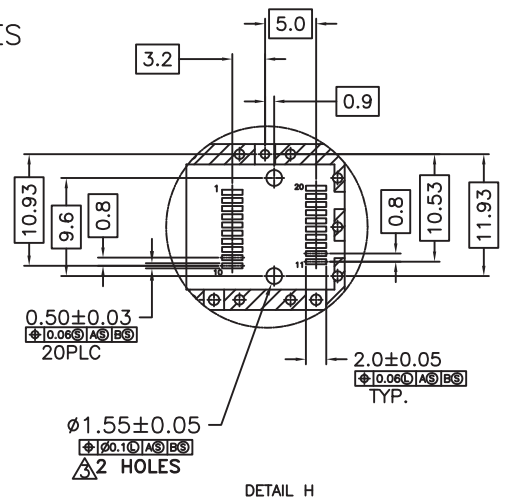

Drafted by:ZhangXuan

Dimensions:mm
Unless otherwise specified, all tolerances are ± 0,25

SFP1x1 cage

Approved By: TSLEE

Part No:SFP011PB

REV.
A

SHEET 2 OF 3

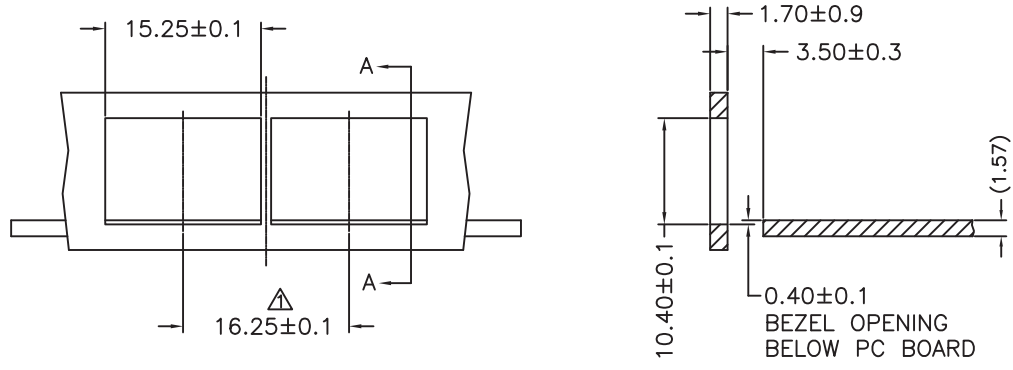

SECTION A-A

RECOMMENDED BEZEL DESIGN

NOTES:
 ▲ MINIMUM PITCH ILLUSTRATED, ENGLISH DIMENSIONS ARE FOR REFERENCE ONLY

	Dimensions:mm Unless otherwise specified, all tolerances are ± 0,25	Approved By: TSLEE	
	SFP1x1 cage	Part No:SFP011PB	REV. A
Drafted by:ZhangXuan	SHEET 3 OF 3		