

SCHEMATICS

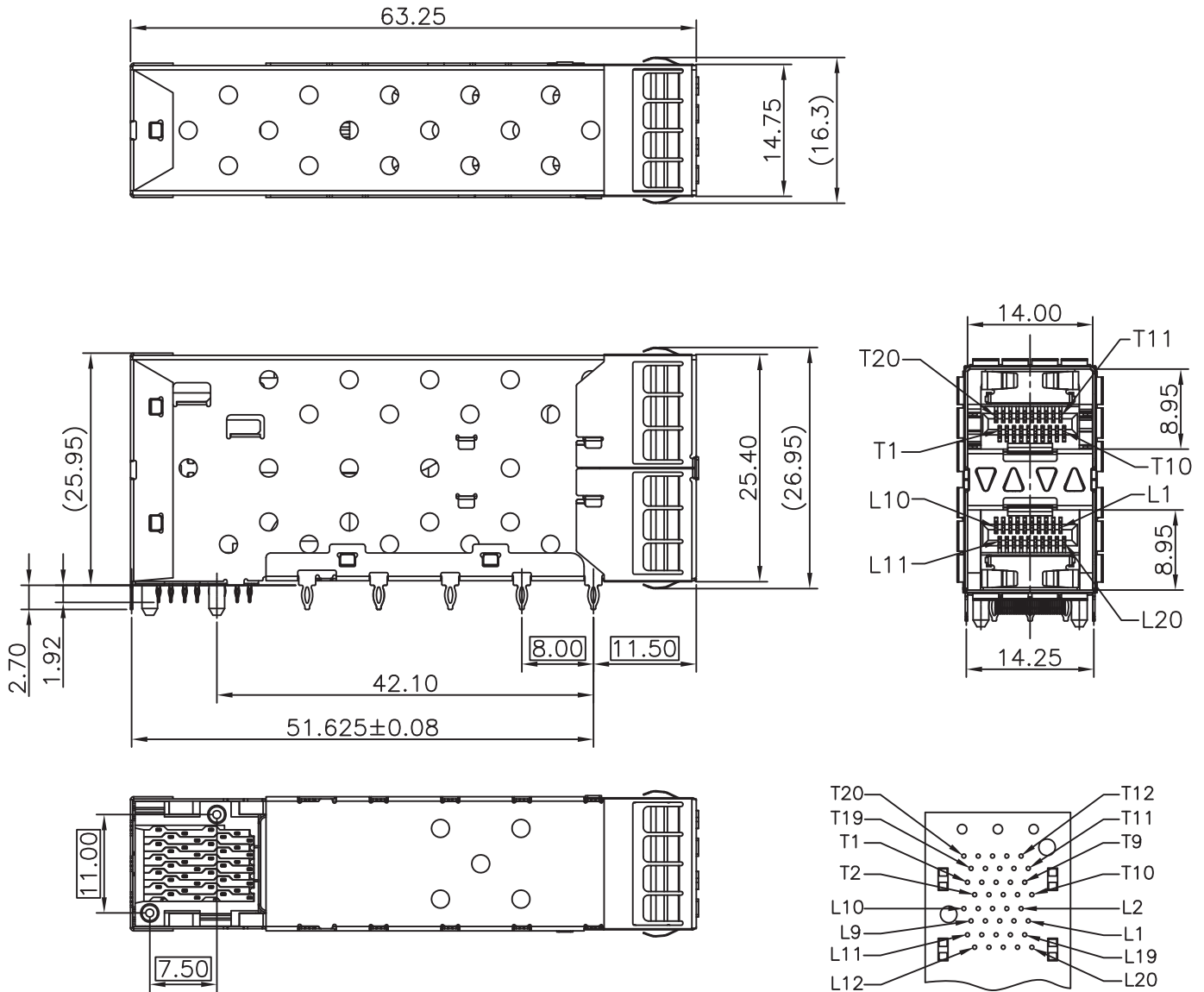

NOTES:
 MATERIAL:
 CAGE: COPPER ALLOY
 CONNECTOR:
 PLASTIC HOUSING: HIGH TEMPERATURE LCP, UL94 V-0.
 LIGHT PIPE: POLYCARBONATE; COLOR: CLEAR
 SPRING: STAINLESS STEEL
 CONTACTS: PHOSPHOR BRONZE
 CONTACT PLATING: 15u" MIN. GOLD ON MATING AREA,
 150u" MATTE TIN ON SOLDER TAILS
 PACKAGING: TRAY PACKAGING.
 TEMPERATURE RANGE: -40°C TO +85°C

CONNECTOR PIN-OUT
 COMPONENT SIDE OF BOARD



Drafted by: ZhangXuan

Dimensions: mm
 Unless otherwise specified, all tolerances are ± 0.25

SFP+Cage 2x1 + Connector

Approved By: TSLEE

Part No: SFPP021PB30

REV.
 A

SHEET 1 OF 4

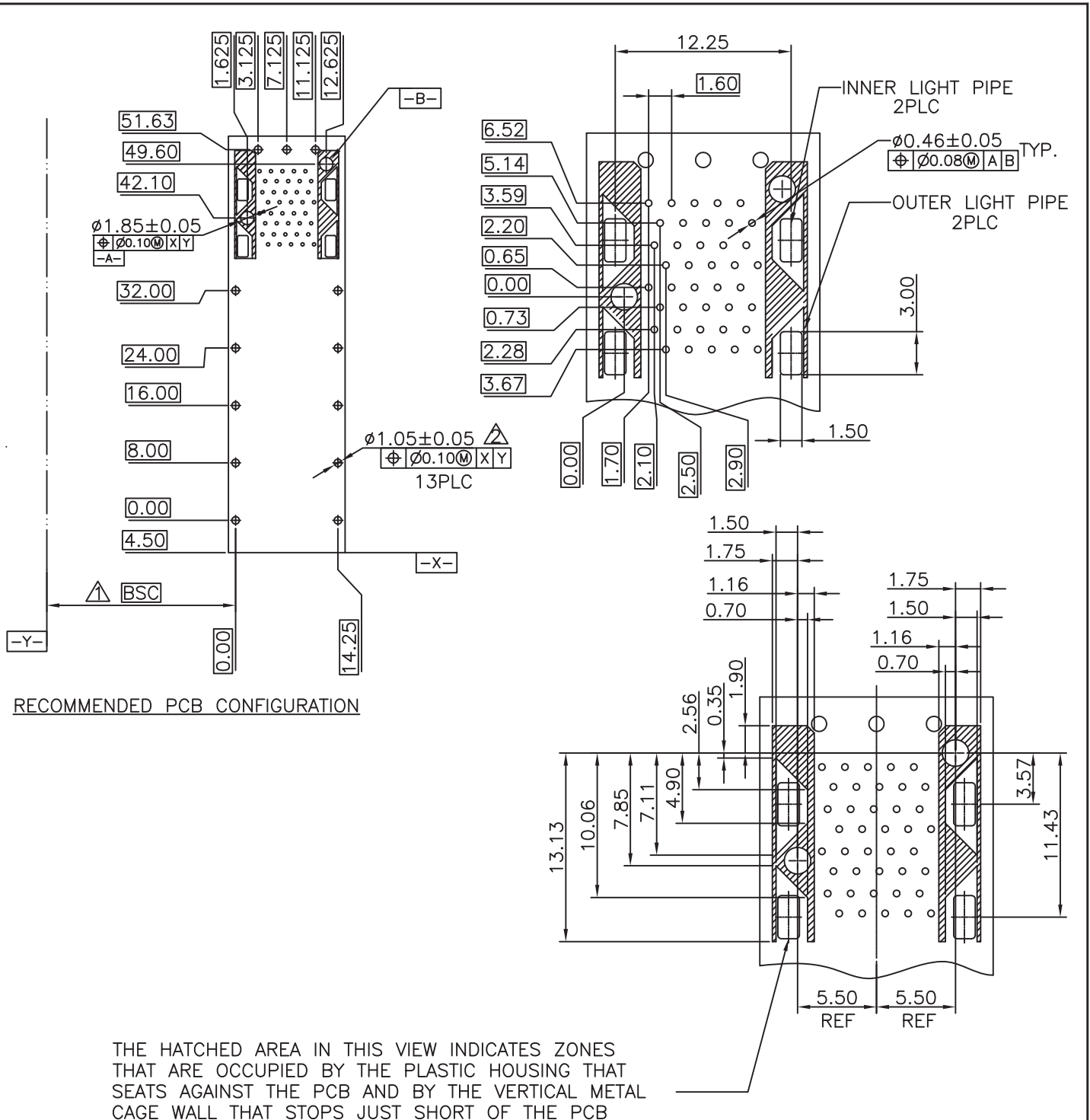

NOTES:

1. DATUM AND BASIC DIMENSIONS ESTABLISHED BY CUSTOMER.
2. 1.05 mm DIAMETER HOLES ARE CHASSIS GROUND .

	Dimensions:mm Unless otherwise specified, all tolerances are ± 0,25	Approved By: TSLEE	
	SFP+ Cage 2x1 + Connector	Part No: SFPP021PB15	REV. A
Drafted by:ZhangXuan	SHEET 2 OF 4		

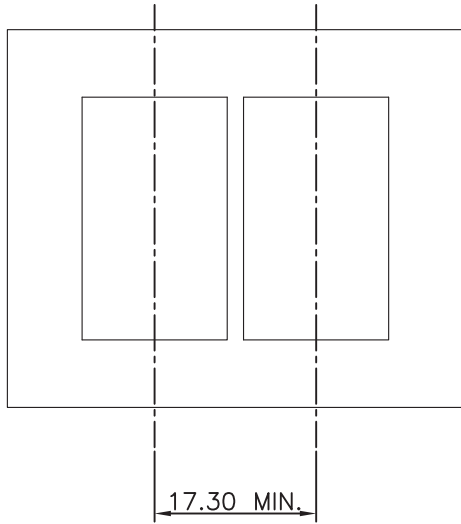
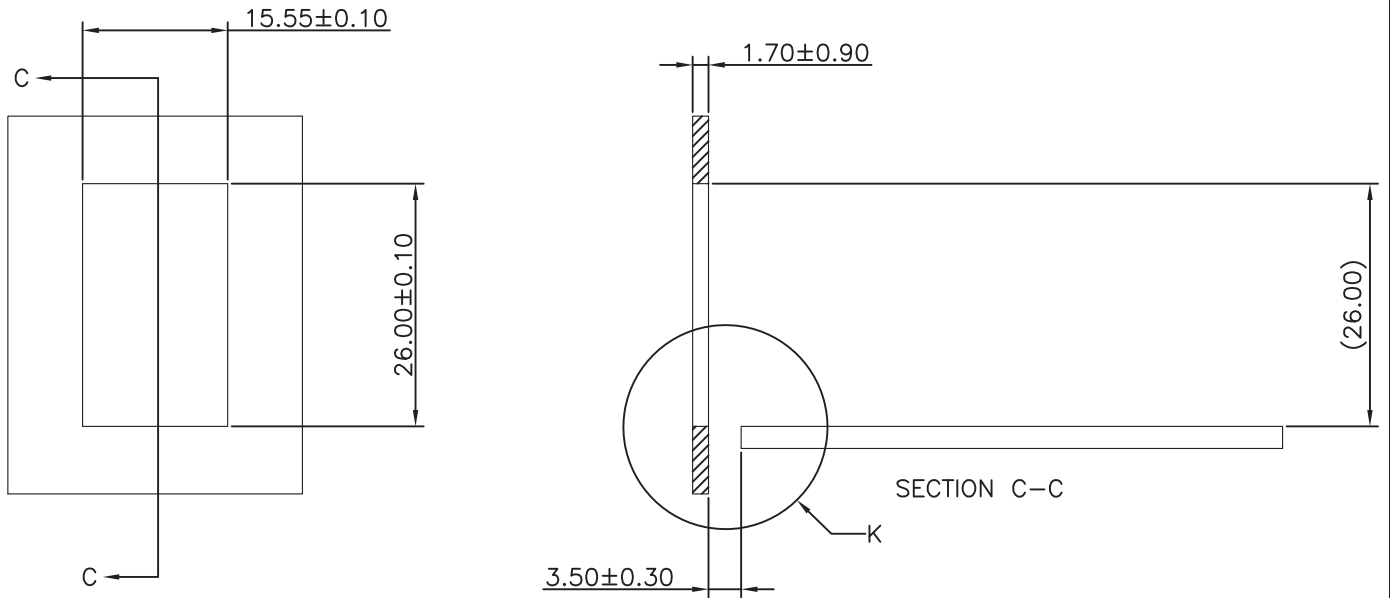

RECOMMENDED BEZEL DESIGN

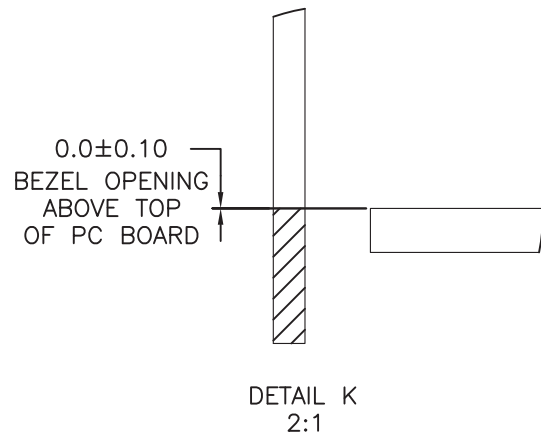

Drafted by: ZhangXuan

Dimensions:mm

Unless otherwise specified, all tolerances are $\pm 0,25$

SFP+ Cage 2x1 + Connector

Approved By: TSLEE

Part No: SFPP021PB15

REV.
A

SHEET 3 OF 4

PACKAGE INFORMATION AND LABEL

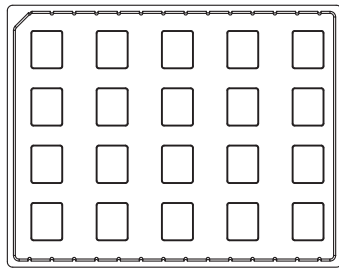

1. PRODUCTS IN TRAYS

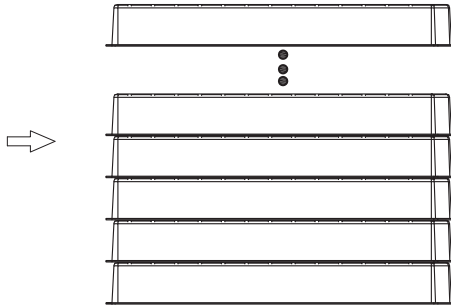

2. TRAYS OVERLAY:
 (THE NEXT TRAY NEED ROTATE 180 DEGREE
 AND
 PUT IT ON PREVIOUS TRAY.)
 (相邻两个吸塑间水平方向成180度摆放)

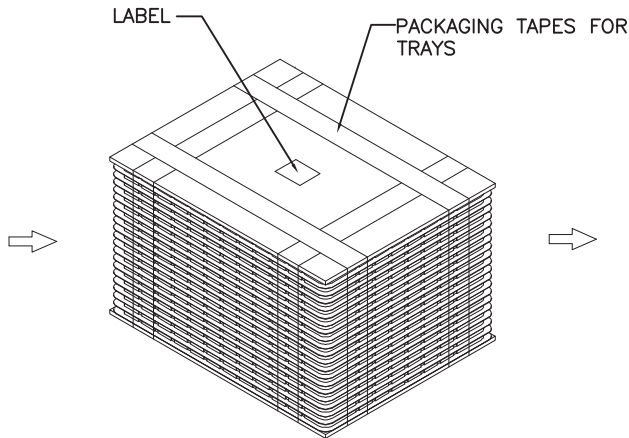

3. LABEL & PACKAGING TAPES FOR TRAYS:

PACKAGING LISTS	
ITEM	Q'TY
PRODUCT	120 PCS
TRAY	6 PCS
BOX(L340*W265*H200MM)	1 PCS
LABLE	2 PCS
PACKAGING TAPES	8 M (ABOUT)

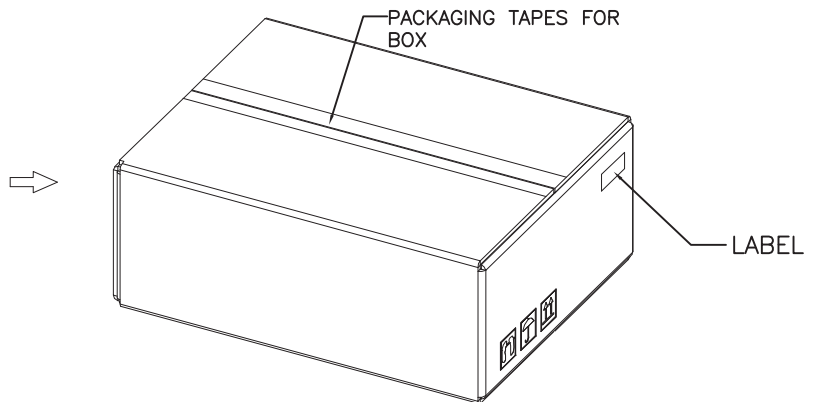

4. LABEL & PACKAGING TAPES FOR BOX

Drafted by:ZhangXuan

Dimensions:mm
 Unless otherwise specified, all tolerances are $\pm 0,25$

SFP+ Cage 2x1 + Connector

Approved By: TSLEE

Part No:SFPP021PB30

REV. A

SHEET 4 OF 4